TB8100 base station

Using a TB8100 in Paging Applications



Contents

1	General Overview	3
2	Applicability	3
3	Functional Description	4
4	System Types	6
	4.1 POCSAG Only System	6
	4.2 Linked Repeater System	7
5	Board Interfaces	8
6	Fitting the Board	9
7	Configuring a POCSAG-only System	10
	7.1 Configuring the Reciter	10
	7.2 Adjusting Audio Output Levels	11
	7.3 Connecting the Encoder	12
8	Troubleshooting	12
9	Connection and Switch Details	13
	TBA101B paging board schematic	17

1 General Overview

TB8100 base stations can be fitted with a TBA101B Paging Application Board. This provides a paging interface and makes it possible for the TB8100 to be used in POCSAG paging applications. Modem or delay line operation is not provided, but the TBA101B is designed to interface to paging controllers with these functions.

For information about the specifications of paging operation, see the TB8100 Specifications Manual.



Note This product can only be used on frequency bands and at power levels which have the appropriate paging compliance. Please consult Tait if you are unsure whether the TBA101B has compliance for your application.

2 Applicability

The TB8100 reciter must be fitted with one of the following system interface boards:

- XBAS0T1 TaitNet (spares code TBA-SP-S0T1)
- XBAS0L0 TaitNet RS-232 (spares code TBA-SP-S0L0)
- XBAS0K0 TaitNet Ethernet (spares code TBA-SP-S0K0)

If the reciter was manufactured before June 2005, check that the system interface board is version 1 or greater. There must also be two pems (threaded holes) on the reciter RF back plate.

The PMU must have a 12 V or 24 V auxiliary power output, to power the TBA101B board; the TBA101B can accept an input voltage of 10.8–24 V.

Basic POCSAG configurations do not require any additional feature licences. However, some specialist configurations may require the Advanced Profiles and Task Manager licence.

3 Functional Description

The TB8100 paging interface accepts a logic level signal that directly drives the RF carrier to either a positive or negative deviation offset. The frequency of this deviation offset is directly related to the logic input. Users should be careful not to drive this signal at any rate other than that approved for the channel it is being used on.

Power is provided to the TBA101B from the reciter system interface board. This can also make power available on the J4 D-range for external equipment.

The DATA line carries the actual paging signal to be transmitted. This signal should be 512, 1200 or 2400 Baud, depending on your speed, RF power levels and compliance system requirements. The paging circuitry in the TBA101B transforms the digital data received into corresponding DC levels and provides them to the reciter.

The Data/Speech logic line determines whether POCSAG signals (via the unbalanced interface) are able to modulate the transmitter. It enables or disables the paging interface logic from driving the TB8100 unbalanced audio input. The external paging controller should drive this line appropriately (refer to [“Board Interfaces” on page 8](#)). The Service Kit lets you configure application-specific signal path characteristics for these audio interfaces.



Note This line **does not** control the audio applied to the balanced line input. You should take precautions to ensure that audio cannot appear on the balanced line input while the base station is transmitting paging signals. Alternatively, switch off the balanced line input in the channel profile in use.

Figure 1 Paging interface block diagram

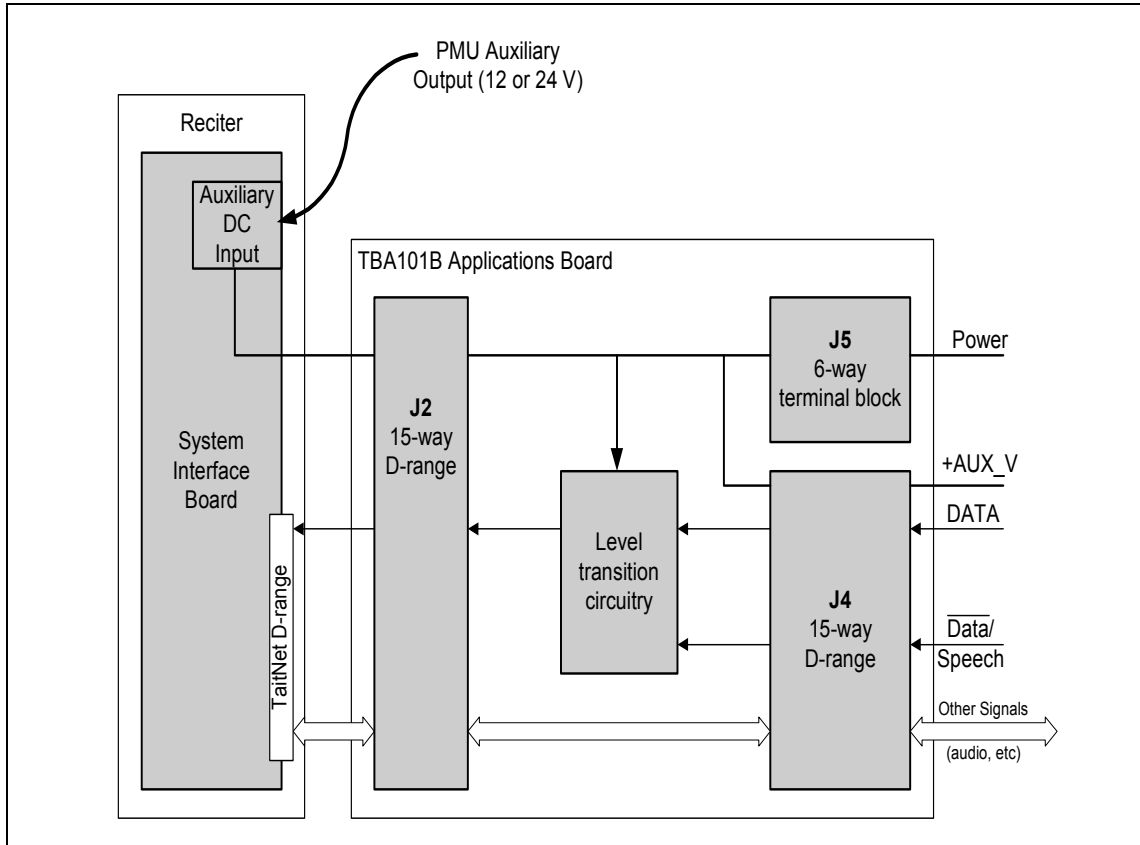

4 System Types

The TBA101B can support the following system types.

4.1 POCSAG Only System

Figure 2 shows a TB8100 channel fitted with a TBA101B that is connected to a third party POCSAG paging encoder.

Figure 2 POCSAG-only system

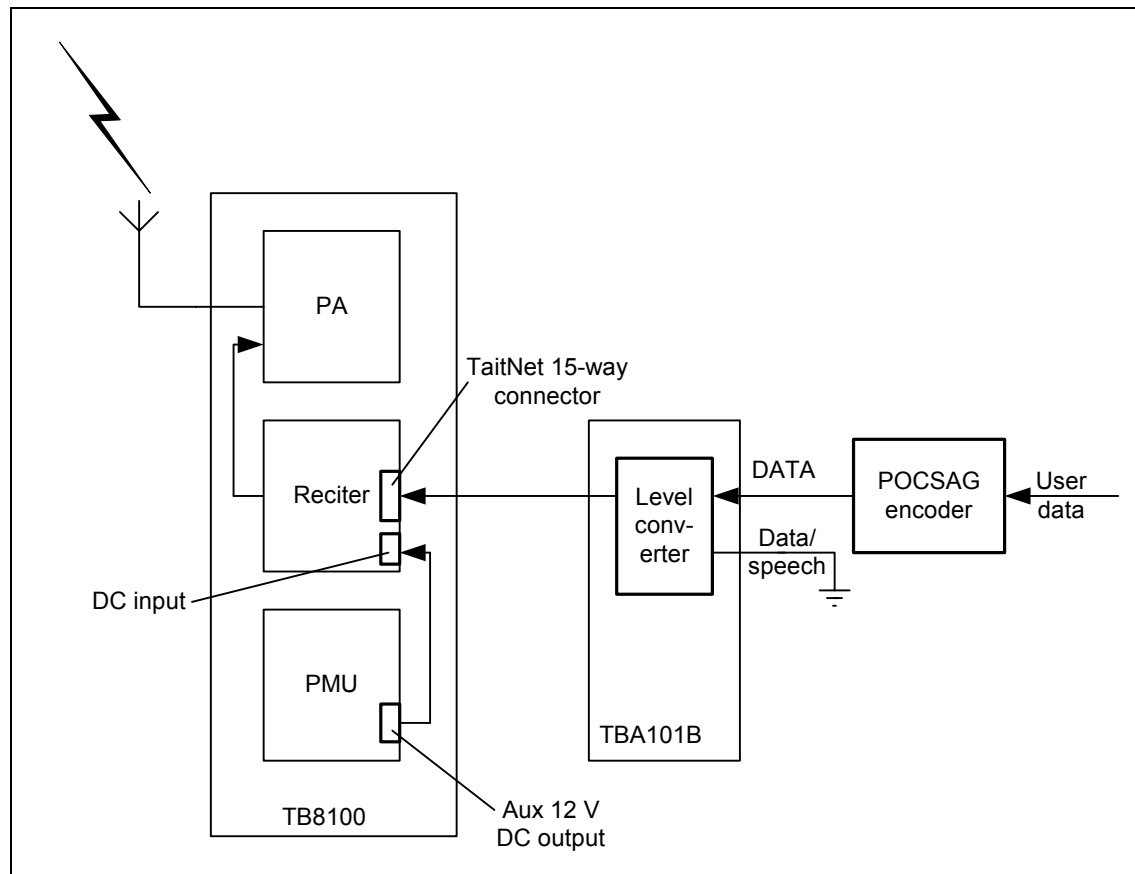

The POCSAG encoder takes the user data stream and inserts it into a paging packet with the associated pager address details. This digital output stream from the encoder is fed to the TBA101B paging application board, where the high/low data stream is converted into a positive and negative carrier deviation by directly DC modulating the TB8100 transmitter via the unbalanced line interface.

The TBA101B POCSAG paging data stream DC output to the TB8100 unbalanced input is only enabled when the Data/speech input on the TBA101B is low. If the Data/Speech input is high, the DC output to the unbalanced input is switched off, allowing the TB8100 'audio path A' to modulate the exciter with a speech signal, without combining the POCSAG deviation as well.

The POCSAG encoder can be powered from the TaitNet interface. The power for this can be obtained from the PMU's auxiliary output if an appropriate DC interface cable from the PMU to the reciter system interface is fitted. Note that the circuitry on the TBA101B also requires this power to operate correctly.

The POCSAG encoder must also drive the TX_KEY pin to enable the TB8100 transmitter, including any RF power ramp-up and ramp-down timing allowances. The TB8100 rise and fall times can be obtained from the Specification Manual, which is available on all TB8100 Product CDs.

4.2 Linked Repeater System

As well as POCSAG-specific signals, the TBA101B provides all the other signals that are available on the TaitNet or TaitNet/RS-232 system interfaces. This makes it possible for the TB8100 to receive a remotely generated modem signal (typically 1200 FSK), pass this signal to an external modem that then drives a POCSAG encoder, as shown in [Figure 3](#).

Figure 3 Linked repeater system

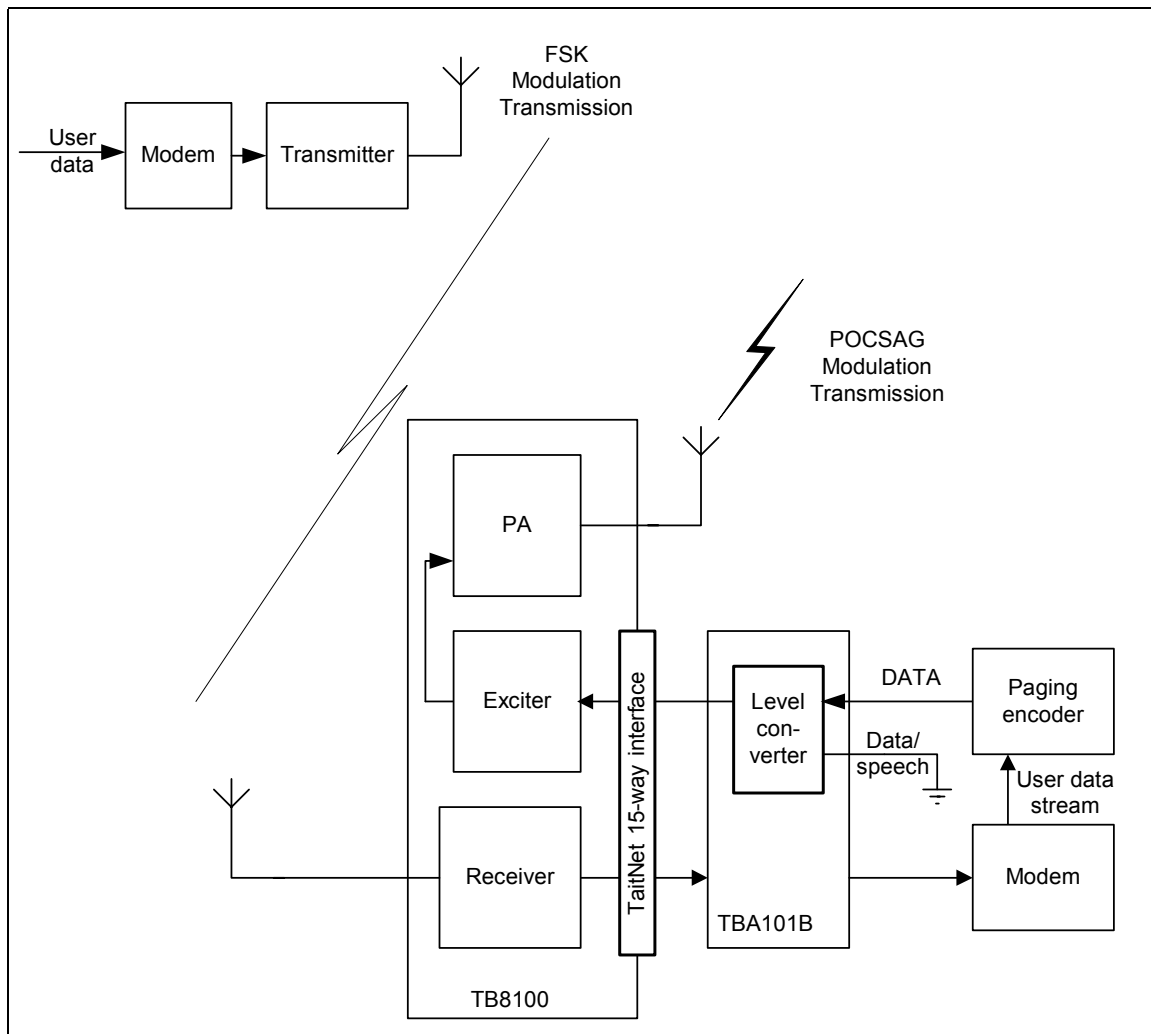

The user data input to the modem (modulation is typically 1200 baud FSK) and link transmitter could be located anywhere within the coverage area of the hill-mounted TB8100, modem, paging encoder and TB101B. The benefit of this system is that the actual POCSAG signal to be transmitted is generated at the TB8100 site. Any noise and interference on the uplink is not re-transmitted. This is especially useful if the paging signal passes through several RF links before reaching the site that it is transmitted from.

5 Board Interfaces

The TBA101B board is fitted with three connectors, two trim pots, and one dip switch. These are shown in [Figure 4](#) and described in [Table 1](#).

Table 1 TBA101B Interfaces

Name	Type	Notes	Location
J2	15-way male D-range	Connects to the D-range on the TaitNet system interface.	bottom of board
J4	15-way female D-range	Provides the interface between the paging controller and the base station	top of board
J5	6-way screw terminal	The inputs and outputs on this connector are duplicates of some of those available on J4	
RV1, RV2	multi-turn trimming pots	Used to set paging DC output levels into the TaitNet system interface	
S1	DIP switch	Configures the operation of the TBA101B.	

Figure 4 Identifying the connectors, trim pots, and DIP switch

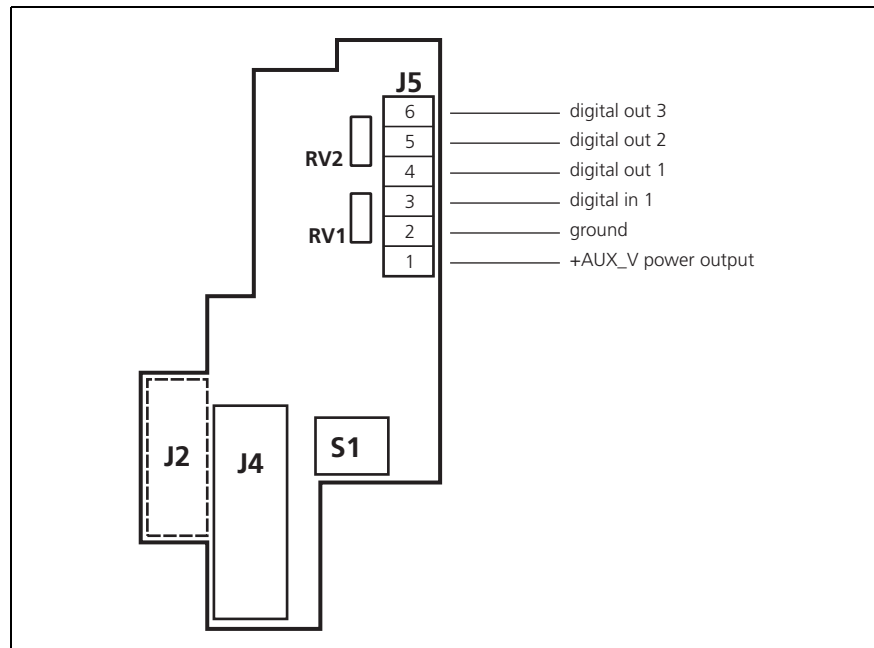

Table 2 TBA101B interface levels

DATA Input	Logic Levels Switching Threshold Input Impedance	3.3V or 5V nominal 1.6V (approximately) ≥5kΩ
Data/Speech Input	Polarity Input Impedance	low to enable data; apply 3.3V or 5V logic high to disable data 2kΩ (approximately)

6 Fitting the Board

Fit the TBA101B board to the rear of the reciter as shown in [Figure 5](#).

1. Screw the two spacers ① into the threaded holes provided on the rear panel of the reciter and tighten securely.
2. Plug the TBA101B board into the 15-way D-range ② and push the plug in firmly. Secure connector J2 to the D-range with the two 4-40 UNC screws ③ provided in the kit.
3. Secure the board to the spacers with the two M3 screws ④ provided.

Figure 5 Fitting the board to the reciter

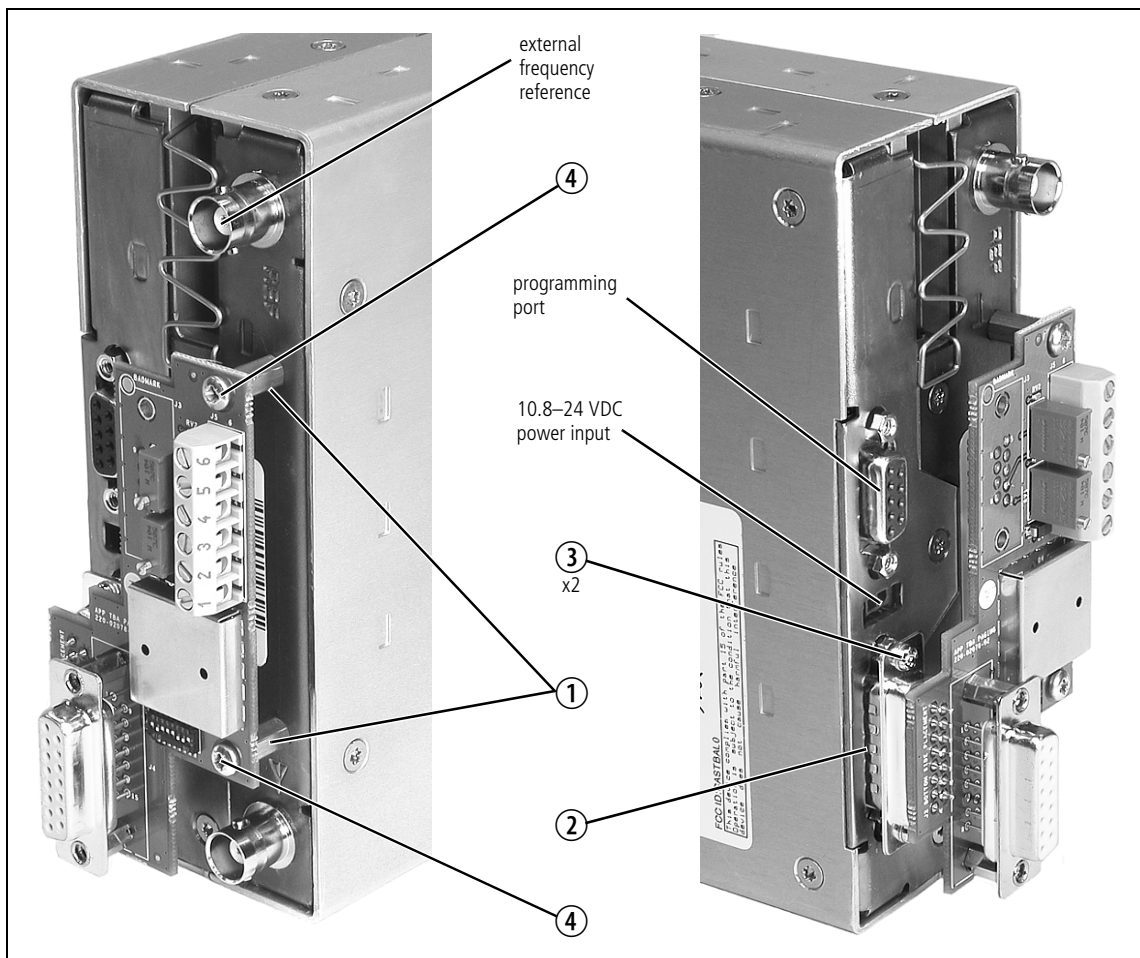

7 Configuring a POCSAG-only System

7.1 Configuring the Reciter

To configure the reciter, follow these steps.

1. Connect to the Reciter using the Service Kit.
2. On the Service Kit, select Monitor > Module Details > Reciter, and verify that the system interface version is 1 or greater.
3. Connect the 12 V or 24 V auxiliary DC output from the PMU to the Reciter. This provides power to the TBA101B. For information on the standard Tait auxiliary DC supply cables available, refer to the “Connection” chapter in the TB8100 Installation and Operation Manual.
4. Configure the PMU auxiliary output so that it is always on. For example, set the Auxiliary power control box to Task Manager, and enable the Task Manager task ‘IF Base Station in Run mode THEN Enable Auxiliary Supply.’
5. On the Signal Path tab of the Edit Channel Profile dialog box, configure the following:
 - Bypass the transmit limiter and low pass filter (select the Bypass check box)
 - Do not have a high pass filter (clear the High pass filter check box)
 - Enable transmit path B (select the Tx path B check box)
 - Set the line level for the Unbalanced line input to 1Vpp

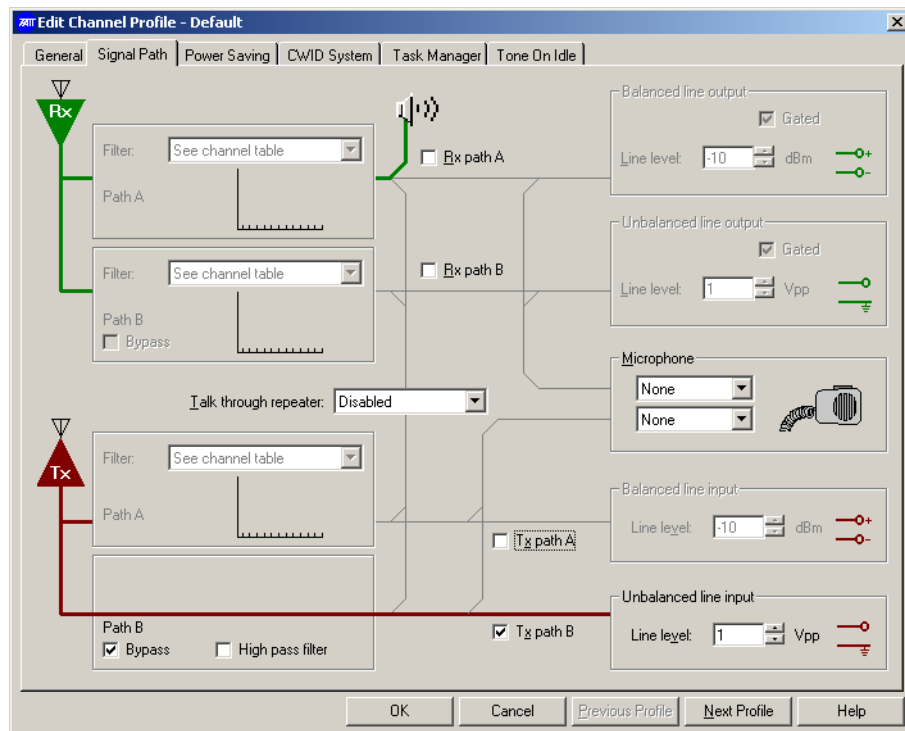

6. Unless required, disable all other audio interfaces on the TB8100.

7.2 Adjusting Audio Output Levels

To adjust the overall POCSAG deviation levels, follow these steps.

1. On the TBA101B, change S1 switches to the following:

Switch	Function	State
1	Forced Enable	ON
2	Standard	ON
3	Standard	ON
4	not used	OFF
5 ^a	Forced High	ON
6 ^a	Forced Low	OFF
7 ^b	Non-Inverted	ON
8 ^b	Inverted	OFF

- a. Turn Switch 5 off before turning Switch 6 on and vice versa.
- b. Turn Switch 7 off before turning Switch 8 on and vice versa.

2. Key the TB8100, either by using the base station calibration and test unit, or by grounding pin 5 of J4.
3. Adjust trim pot RV1 until the desired deviation is reached (this is usually +90% of full system deviation, for example +4.5 kHz from the centre frequency for a wide-band channel).
4. Turn S1 switch 5 OFF and switch 6 ON.
5. Adjust trim pot RV2 until the desired negative deviation is reached (this is usually -90% of full system deviation, for example -4.5 kHz from the centre frequency for a wide-band channel).
6. Turn S1 switch 1 and switch 6 OFF.



Note If the base station is to be used as part of a Simulcast paging system, the deviations of all the base stations in the system must be matched to within 5%.

7.3 Connecting the Encoder

Once you have adjusted the deviation levels as described above, follow these steps to make the paging system operational.

1. Connect the DATA line from the POCSAG encoder to pin 6 of J4.
2. Connect the Data/speech line to pin 11 of J3 (this allows the paging controller to switch the transmitter output between POCSAG and speech). Alternatively, permanently enable POCSAG modulation by shorting pin 11 to ground or (preferably) by turning S1 switch 1 ON.
3. Connect the $\overline{\text{PTT}}$ signal from the encoder to pin 5 of J4.
4. If required, connect the power input lead of the encoder to pin 9 of J4.
5. Connect the encoder ground to pin 15 of J4.

8 Troubleshooting

Problem	Solution
The desired deviation cannot be reached despite fully adjusting the trimming pot.	Ensure that the reciter and the SIF has been correctly calibrated
There is no response from the pager despite having the correct deviations set.	The output from the POGSAC encoder may require inversion to be recognised by the pager. Turn switch 7 off and switch 8 on for S1. Verify that the encoder has been set to the correct Baud rate and is receiving the correct protocol.

9 Connection and Switch Details

The following provides reference information about the connector pins and the dip switch.

Table 3 Pin allocations for the 15-way D-range J4: reciter fitted with TaitNet or TaitNet RS-232 board

Pin	Signal Name	Signal Type	Notes
1	Rx line out +	600 ohm audio output	transformer isolated line
2	Rx line out –	600 ohm audio output	
3	Rx audio out	audio output	
4	Rx gate	output	open collector
5	Tx key	input	active low
6	DATA	data input	
7	Tx line in +	600 ohm audio input	transformer isolated line
8	Tx line in –	600 ohm audio input	
9	+AUX_V	power output	from auxiliary DC input
10	digital out 3	output	open collector
11	data / speech	enables POCSAG on the Tx output	enabled = low disabled = high
12	digital out 1 ^a	output	open collector
13	digital out 2		open collector
14	digital in 1	input	5 V TTL logic, active low
15	ground	ground	

- a. If a base station with a 12 V PA is configured for Deep Sleep, digital out 1 is dedicated to Power Saving control and cannot be used for any other Task Manager function.

Table 4 Pin allocations for the 15-way D-range J4: reciter fitted with TaitNet Ethernet board

Pin	Signal Name	Signal Type	Notes
1	Rx line out +	600 ohm audio output	transformer isolated line
2	Rx line out –		
3	Rx audio out	audio output	
4	Rx gate	output	open collector
5	Tx key	input	active low
6	DATA	data input	
7	Tx line in +	600 ohm audio input	transformer isolated line
8	Tx line in –		
9	+AUX_V	power output	from auxiliary DC input
10	digital in/out 1 ^{ab}	input	5V TTL logic, active low
11	data / speech	enables POCSAG on the Tx output	enabled = low disabled = high
12	digital in/out 2 ^a	input	5V TTL logic, active low
13	digital in/out 3 ^a		
14	digital in/out 4 ^a		
15	ground	ground	

- a. Digital inputs 1, 2, 3, and 4 may also be configured as outputs using a Task Manager statement. For more details refer to "Digital Interface" in the "Connection" chapter of the Installation and Operation Manual, and to the Service Kit documentation. For more information on the TaitNet Ethernet system interface board, refer to TN-1142-AN.
- b. If a base station with a 12V PA is configured for Deep Sleep, digital out 1 is dedicated to Power Saving control and cannot be used for any other Task Manager function.



Important

On the TaitNet Ethernet system interface board, pins 3, 4, 5, and 6 can be configured for Rx gate, Tx key and unbalanced audio, **or** E&M signalling. Although the configuration of pins 3, 4, and 5 does not affect the operation of the TBA101B paging board, you must configure pin 6 as Tx audio in. Refer to TN-1142-AN for more details.

Table 5 Pin allocations for the 6-way terminal block J5

Pin	TaitNet 15	Signal Type	Notes
1	+AUX_V	Power Output	10.5 to 33V
2	Ground	Ground	
3	Digital In 1	Input	Maximum +20 V
4	Digital Out 1	Output	Open Collector
5	Digital Out 2	Output	Open Collector
6	Digital Out 3	Output	Open Collector

Table 6 Dip Switch S1

Switch	Function	Description	Operating State
1	Forced Enable	POCSAG is always enabled	Depends on the application. Switch ON if there is no external control.
2	Enable	Enable POCSAG by external signal	ON
3	Disable	POCSAG is disabled	OFF
4	Tait use only	Leave OFF	OFF
5 ^a	Forced High	Set positive deviation	OFF
6 ^a	Forced Low	Set negative deviation	OFF
7 ^b	Non-Inverted		ON
8 ^b	Inverted		OFF

- a. Turn Switch 5 off before turning Switch 6 on and vice versa.
b. Turn Switch 7 off before turning Switch 8 on and vice versa.

Figure 6 TBA101B paging board schematic

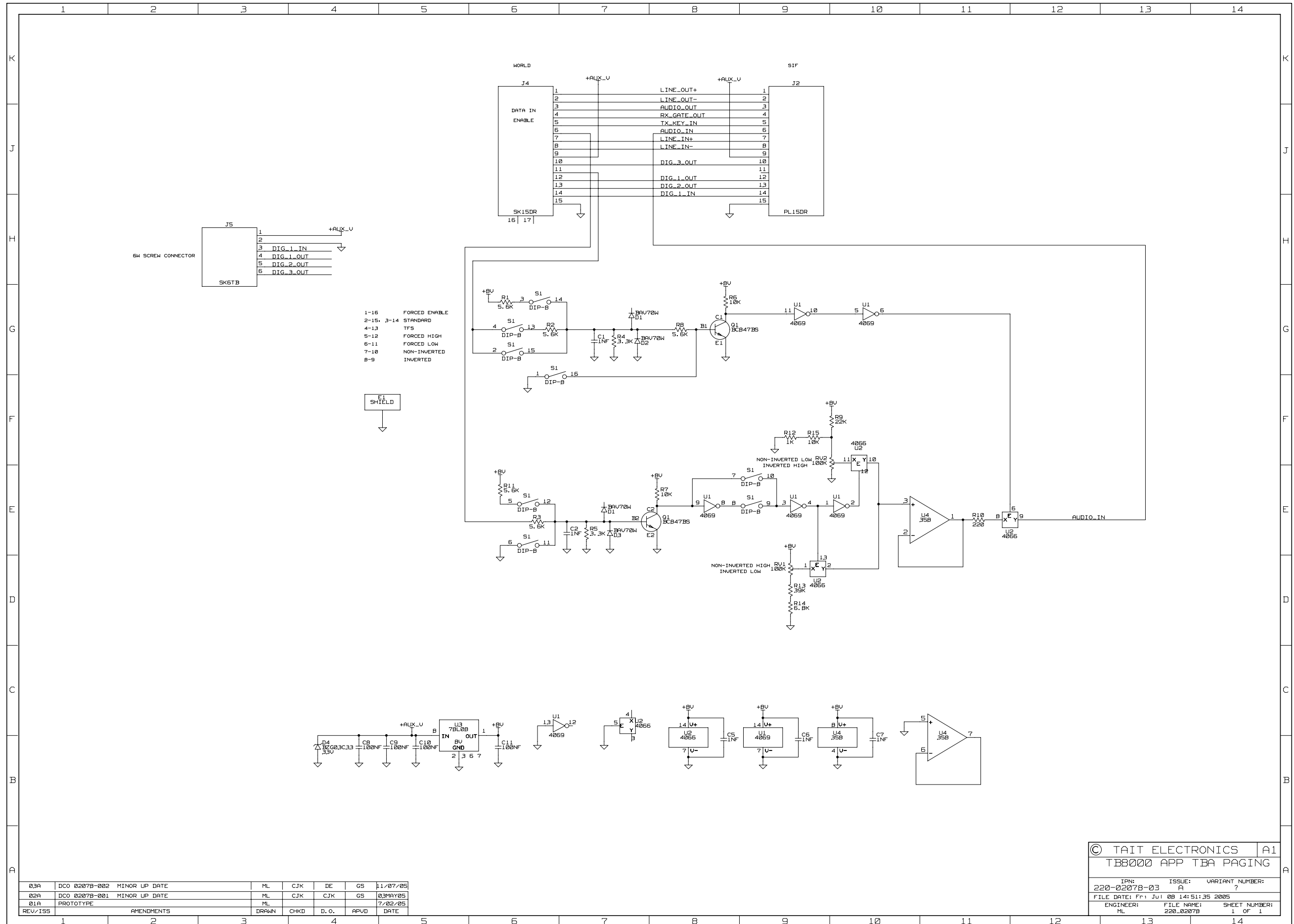

03A	DCO 0207B-002	MINOR UP DATE	ML	CJK	DE	GS	11/07/05
02A	DCO 0207B-001	MINOR UP DATE	ML	CJK	CJK	GS	03MAY05
01A	PROTOTYPE		ML			GS	7/02/05
REV/ISS	AMENDMENTS		DRAWN	CHKD	D. O.	APUD	DATE

© TAIT ELECTRONICS		A1
TBB000 APP TBA PAGING		
IPN:	ISSUE:	VARIANT NUMBER:
220-0207B-03	A	?
FILE DATE: Fri Jul 08 14:51:35 2005		
ENGINEER: ML	FILE NAME: 220_0207B	SHEET NUMBER: 1 OF 1

Publication Information

Issuing Authority This TN was issued by: Kurt Ebrecht
Technical Publications Manager

Distribution Level Associate, Associate System Integrator, Accredited Service Centre, Accredited Service Centre System Integrator, or Tait Only.

Publication History

Publication Date	Author
5 May 2006	D Reynolds

Amendment Record

Publication Date	Page	Amendment
14 July 2005		First release
5 May 2006	2 3 4 8 9 13 14 15	Table of Contents added reference to TaitNet Ethernet board added description of Data/Speech logic line changed RV1 and RV2 correctly identified in Figure 4 interface levels added in Table 2 description of pin 11 changed in Table 3 pin allocations for TaitNet Ethernet board added description of pin 4 changed in Table 6

Tait Contact Information

Corporate Head Office New Zealand Tait Electronics Limited
P.O. Box 1645
Christchurch
New Zealand

For the address and telephone number of regional offices, refer to the TaitWorld website:

Website: <http://www.taitworld.com>

Technical Support For assistance with specific technical issues, contact Technical Support:
E-mail: support@taitworld.com
Website: <http://support.taitworld.com>